

Stretching, Compression and Fluids

Questions

Q1.

A diver is swimming underwater in a lake.

The diver wears the meter shown in Figure 3.

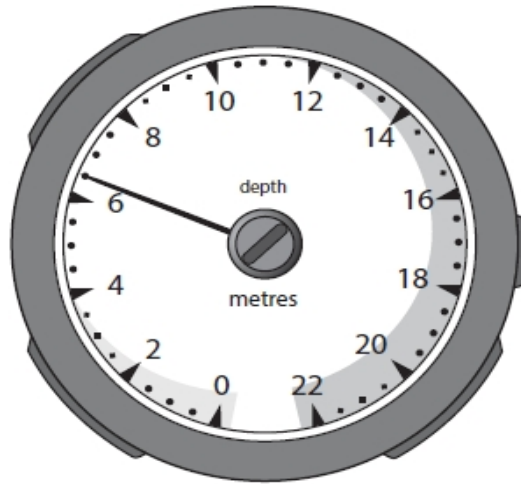

Figure 3

(i) The meter shows the depth of the diver below the surface of the water.

State the depth shown on the meter in Figure 3.
State the unit.

(2)

depth =unit =

(ii) State how the pressure of the water on the diver changes as the diver swims down from the surface of the lake.

(1)

.....
.....

(iii) State why the total pressure on the diver is greater than just the pressure due to the water above the diver.

(1)

.....
.....

(Total for question = 4 marks)

Q2.

Figure 14 shows a spring standing on a table.

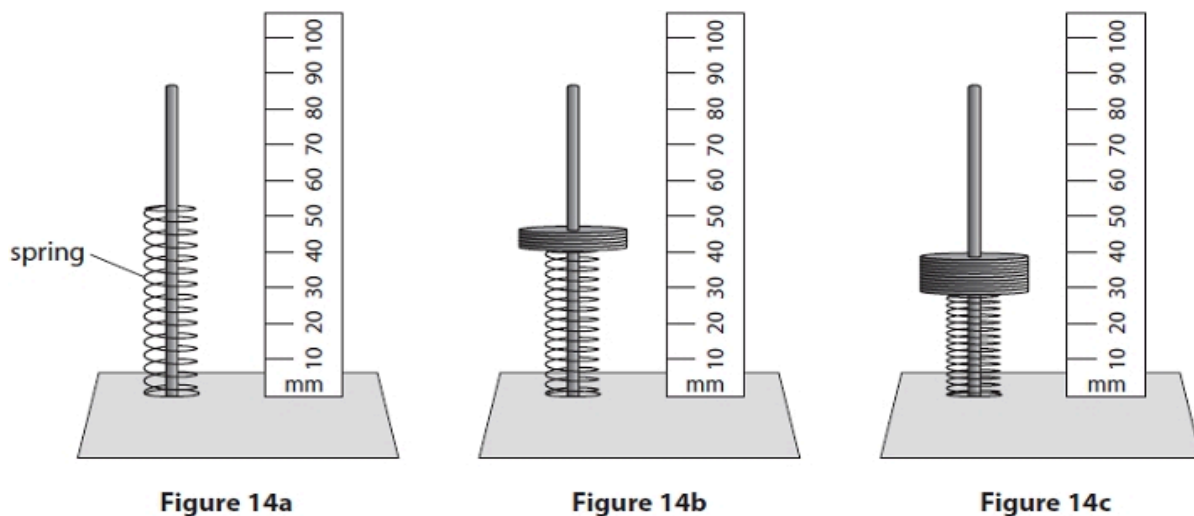

Weights are added to the spring as shown in Figures 14b and 14c.

(i) Estimate the original length of the spring as shown in Figure 14a.

(1)

original length = mm

(ii) Describe how the reduction in the length of the spring when weights are added can be determined.

(2)

.....

.....

.....

.....

(iii) State two ways that the experimental procedure could be improved.

(2)

1

.....

2

.....

(iv) Give one reason why the reduction in length eventually reaches a limit as more weights are added.

(1)

.....

.....

(Total for question = 6 marks)

Q3.

A student sets up the apparatus shown in Figure 9.

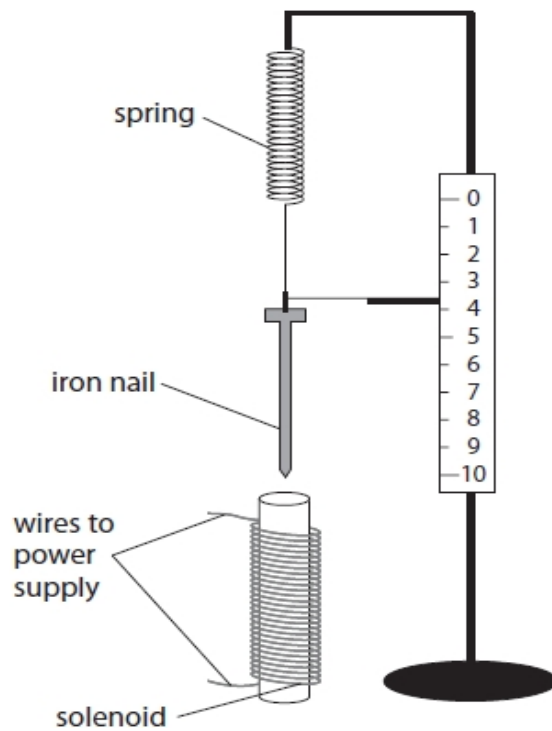

Figure 9

(i) When the current in the solenoid is switched on, the solenoid attracts the iron nail.

Describe how the student could use this apparatus to investigate how the size of the current in the solenoid affects the force of attraction between the solenoid and the iron nail.

(4)

.....

.....

.....

.....

.....

.....

(ii) The spring constant of a different spring is 24 N/m.

The spring is extended from its unstretched length by 12 cm.

Calculate the energy transferred in extending the spring by 12 cm.

Use an equation selected from the list of equations at the end of this paper.

(2)

energy transferred = J

(Total for question = 6 marks)

Q4.

The graph in Figure 14 shows the variation in atmospheric pressure with the height above sea level.

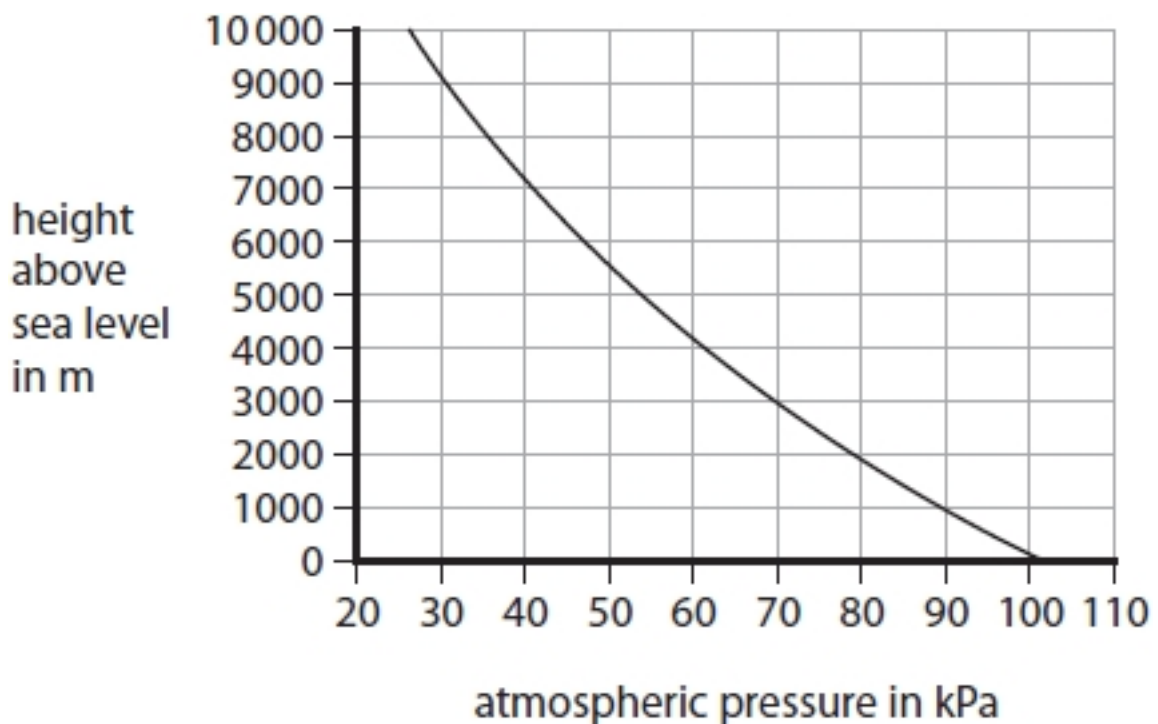

Figure 14

(i) Use the graph to estimate the atmospheric pressure at 3000 m above sea level.

(1)

atmospheric pressure = kPa

15.1 Stretching, Compression and Fluids

(ii) Use the graph to estimate the atmospheric pressure at 6000 m above sea level.

(1)

atmospheric pressure = kPa

(iii) Suggest a reason why the atmospheric pressure decreases with height above sea level.

(1)

.....
.....

(Total for question = 3 marks)

Q5.

An aeroplane takes off from the ground.

State two factors that affect the pressure of the atmosphere on the aeroplane as the aeroplane goes higher in the atmosphere.

(2)

1

.....

2

.....

(Total for question = 2 marks)

Q6.

Figure 10 shows a toy used to launch a ball.

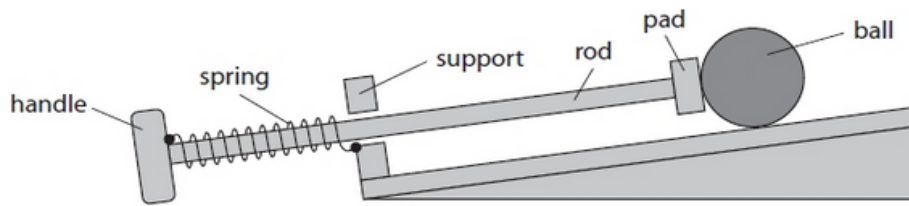

Figure 10

One end of the spring is fixed to the handle.

The other end of the spring is fixed to the support.

A child pulls the handle, stretching the spring.

Figure 11 shows the toy with the spring stretched.

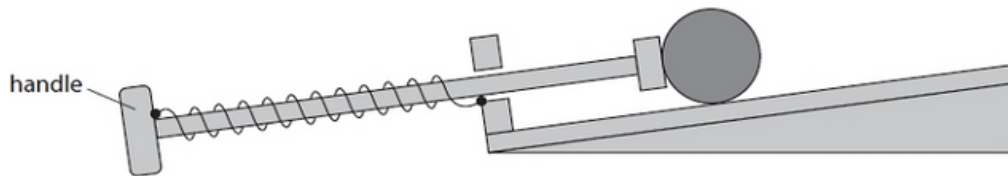
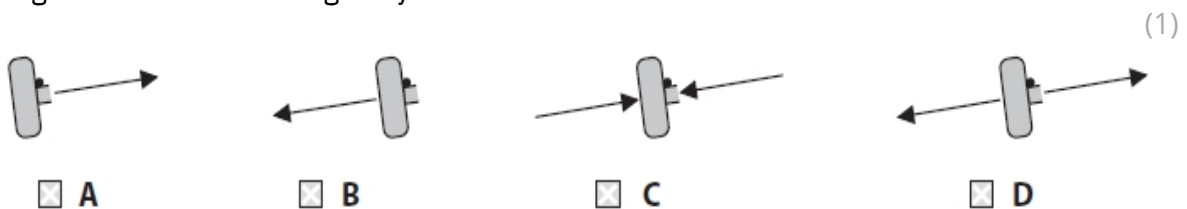

Figure 11

(i) Which of these shows the forces acting on the handle when the child keeps the spring stretched?

Ignore the force due to gravity.



(ii) In Figure 11, the extension of the spring is 0.070 m.

The spring constant (k) is 20 N/m.

Calculate the force used to extend the spring.

Use the equation

$$\text{force} = k \times \text{extension}$$

(2)

force = N

(Total for question = 3 marks)

Q7.

Figure 3 shows a diver swimming in a lake.

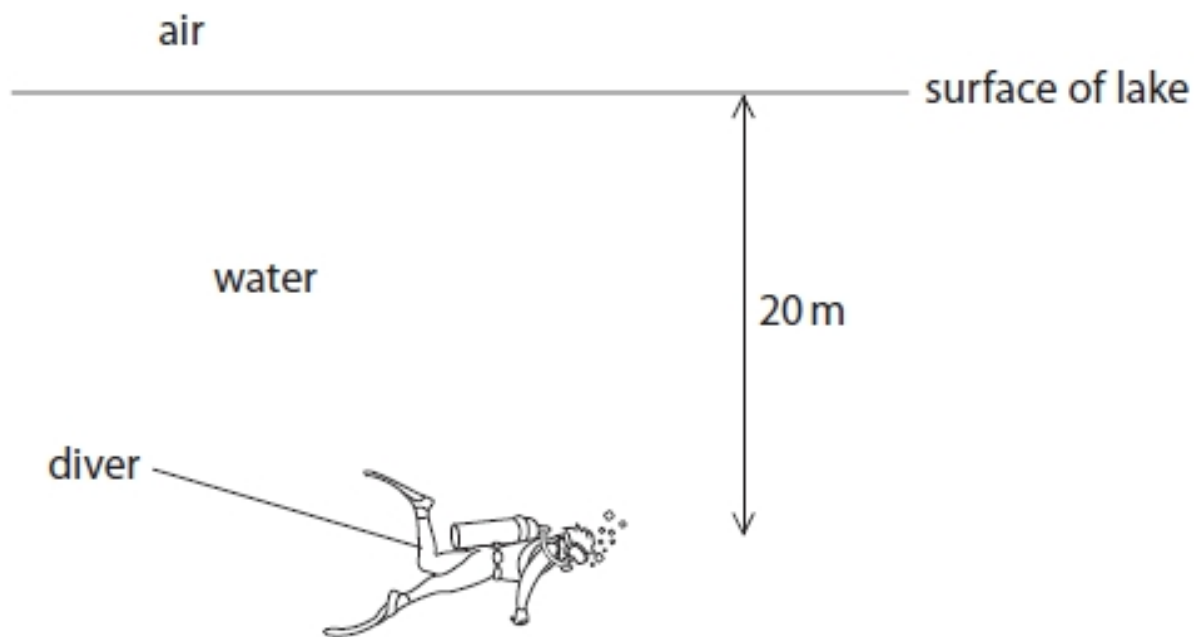
**Figure 3**

The pressure on the diver is due to both the water above him and the Earth's atmosphere.

The pressure of air on the surface of the water is one atmosphere. 10 m of water is equivalent to one atmosphere.

How many atmospheres of pressure will be on the diver at a depth 20 m?

(1)

- A 1
- B 2
- C 3
- D 4

(Total for question = 1 mark)

Q8.

Figure 13 shows a diagram of a device for lifting heavy loads.

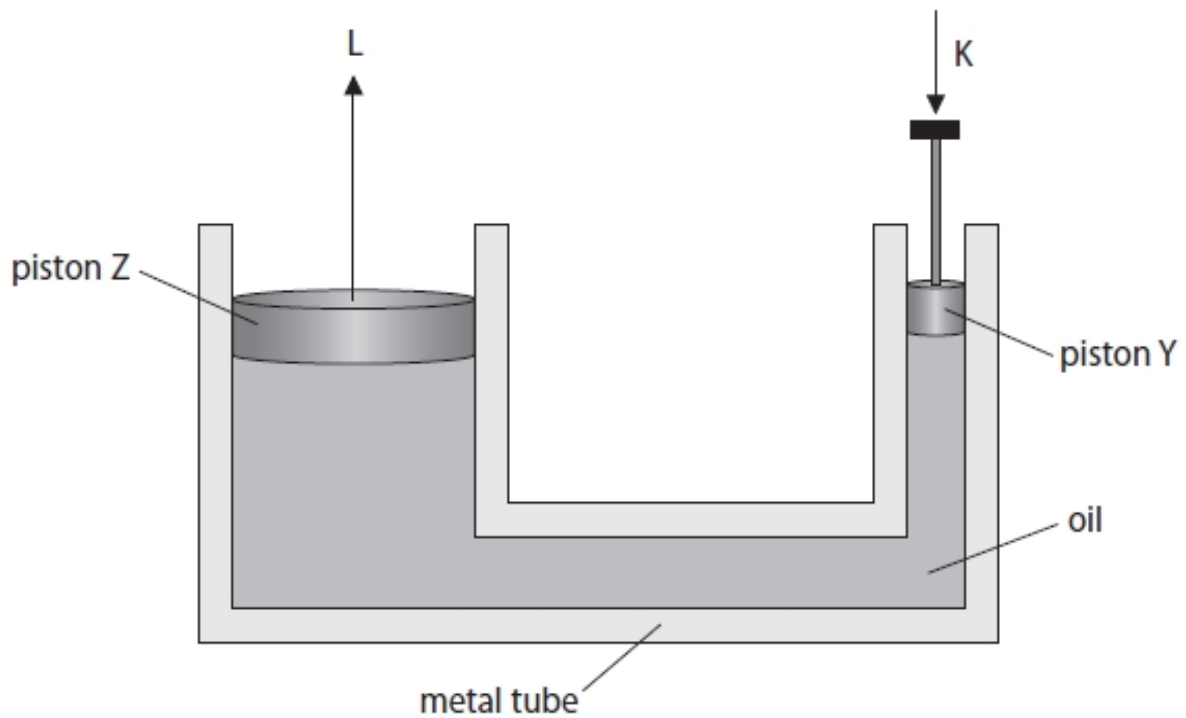

Figure 13

The metal tube is filled with oil.

The piston Y is pushed down with a force K.

This produces a force L on piston Z.

The pressure exerted on the oil by piston Y is the same as the pressure exerted by the oil on piston Z.

Explain the difference between the size of force K and the size of force L.

(3)

.....

.....

.....

.....

.....

.....

(Total for question = 3 marks)

Q9.

*Figure 28 shows a cross-section of a boat floating in water and the same boat with a load inside.

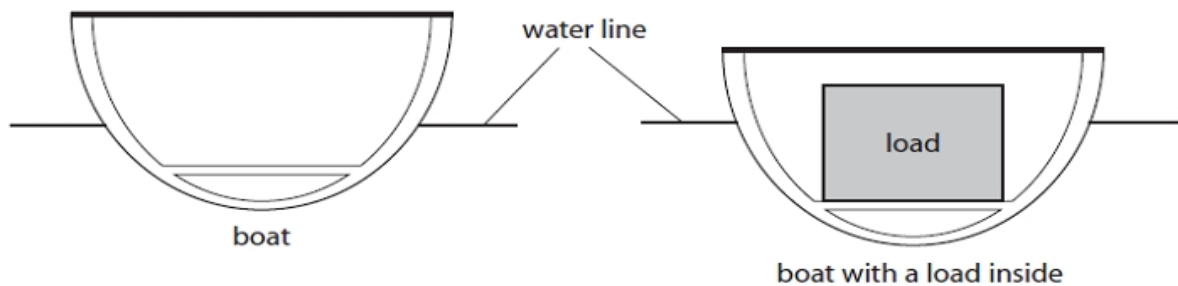

Figure 28

The boat floats lower in the water when there is a load inside the boat.

Explain why the boat floats in water and why the boat floats lower in the water when there is a load inside the boat.

You may add to the diagram to help with your answer.

(6)

.....

.....

.....

.....

.....

.....

.....

.....

.....

.....

.....

.....

.....

.....

.....

.....

.....

.....

.....

.....

.....

.....

.....

(Total for question = 6 marks)

Q10.

Figure 11 shows two drawings of the same person on a bed.

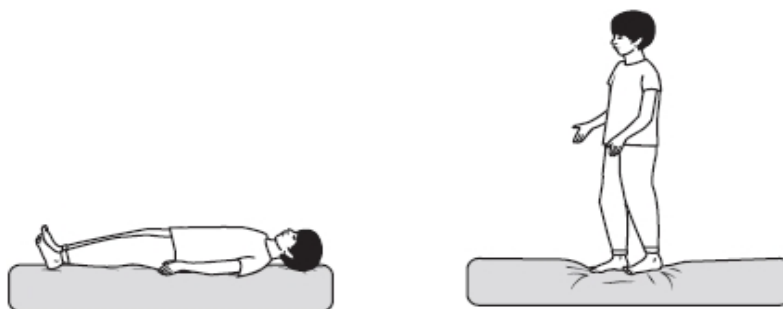

Figure 11

Explain why the person exerts a different pressure on the bed when standing up than when lying down.

(2)

.....

.....

.....

.....

(Total for question = 2 marks)

Q11.

Another spring has a spring constant of 250 N/m. Calculate the work done in stretching the spring by 0.30 m. State the unit.

Use the equation

$$E = \frac{1}{2} \times k \times x^2$$

(3)

work done in stretching the spring = unit

(Total for question = 3 marks)

Q12.

A weight of 4.0 N is used to extend a spring.

The extension of the spring is 0.06 m.

(i) Calculate the spring constant, k , of the spring.

Use the equation

$$F = k \times x$$

(3)

spring constant = N/m

(ii) State what measurements should be made to determine the extension of the spring produced by the 4.0 N weight.

(2)

.....

.....

.....

.....

(Total for question = 5 marks)

Q13.

Figure 26 shows a glass U-tube containing water of density 1000 kg/m^3 .

The water levels are the same on both sides of the U-tube.

Both ends of the U-tube are open to the atmosphere.

Atmospheric pressure is $101\,000 \text{ N/m}^2$.

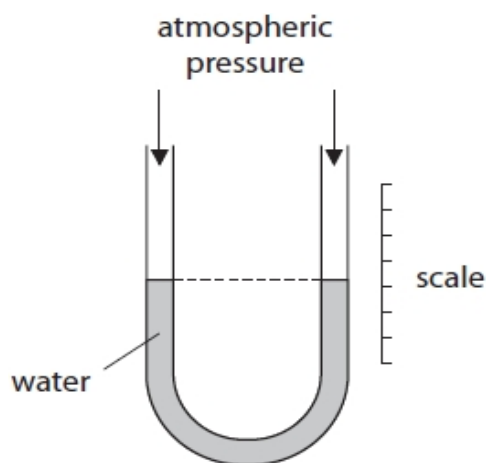

Figure 26

Figure 27 shows the U-tube with one side connected to a gas supply.

The difference in the levels of water, h , is 0.200 m .

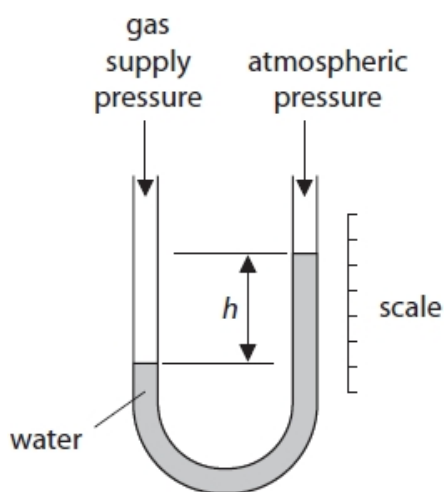

Figure 27

15.1 Stretching, Compression and Fluids

(i) Calculate the gas supply pressure.

Use an equation selected from the list of equations at the end of the paper.

(3)

pressure of gas supply = N/m²

(ii) The measurement is repeated using a U-tube of larger cross-sectional area.

Explain why the value of h does not change.

(2)

.....
.....
.....
.....

(Total for question = 5 marks)

Q14.

A spring is extended.

A force of 0.50 N gives an extension of 13 mm.

Calculate the spring constant k in N/m.

(3)

spring constant $k = \dots\dots\dots$ N/m

(Total for question = 3 marks)

Q15.

* Figure 16 illustrates an effect that can be explained using the ideas of pressure, force and area.

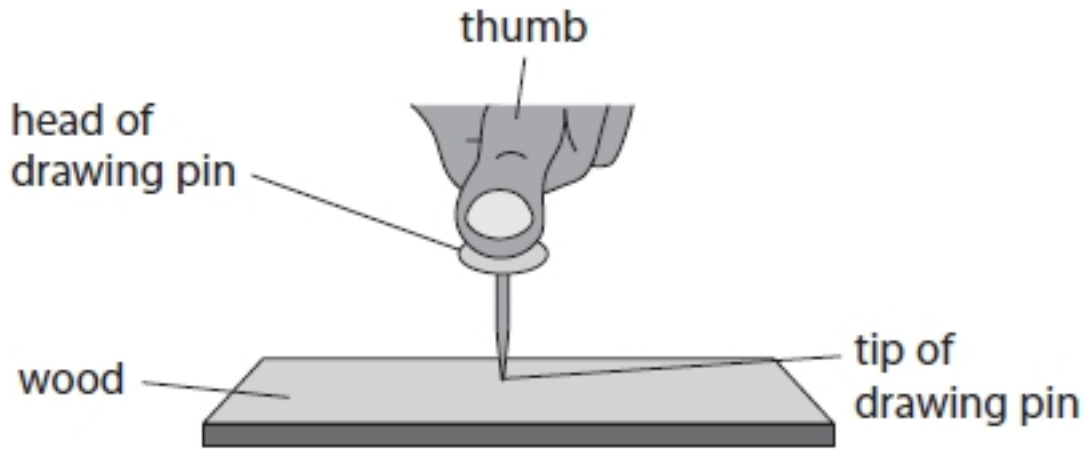

Figure 16

Explain why the tip of the drawing pin goes into the wood but the head of the drawing pin does not go into the thumb.

(6)

.....

.....

.....

.....

.....

.....

.....

.....

.....

.....

.....

.....

.....

.....

(Total for question = 6 marks)

Q16.

Figure 8 shows some water in a tank.

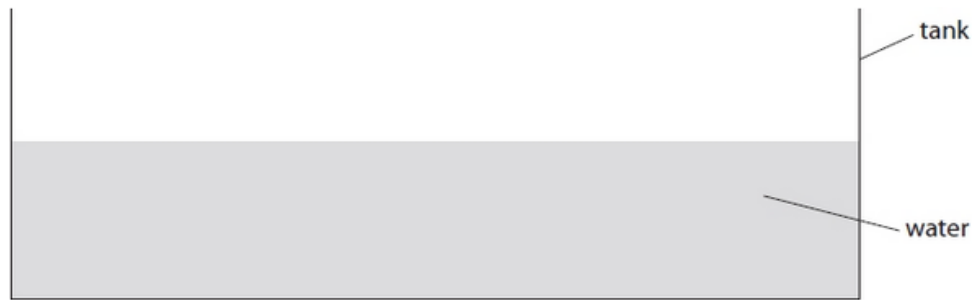

Figure 8

(i) The bottom of the tank has an area of 0.80 m^2 . The force on the bottom of the tank, due to the water, is 2400 N . Calculate the pressure, due to the water, on the bottom of the tank.

(3)

pressure = Pa

(ii) More water is added to the tank.

Explain how the pressure on the bottom of the tank changes when more water is added to the tank.

(2)

.....

.....

.....

.....

(iii) Figure 9 shows an object on the bottom of the tank of water.

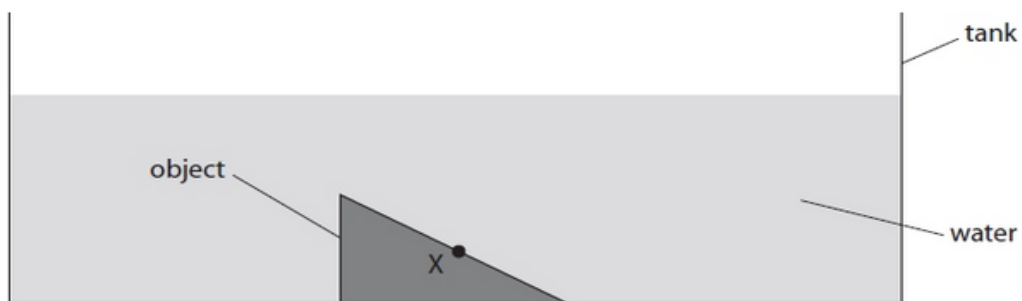

Figure 9

Draw an arrow on Figure 9 to show the direction of the force exerted by the water on the surface of the object at point X.

(1)

(Total for question = 6 marks)

Mark Scheme – Stretching, Compression and Fluids

Q1.

Question number	Answer	Additional guidance	Mark
i	6.5 (1) m (1)	metres / meters allow M independent marks	(2)
Question number	Answer	Additional guidance	Mark
ii	the pressure increases		(1)
Question number	Answer	Additional guidance	Mark
iii	there is additional pressure due to the atmosphere		(1)

Q2.

Question number	Answer	Additional guidance	Mark
(i)	50.0 to 55.0 (mm) inclusive		(1)

Question number	Answer	Additional guidance	Mark
(ii)	a description including note the original length (1) note the final length and subtract (1)		(2)

Question number	Answer	Additional guidance	Mark
(iii)	any two from: use a ruler with a smaller/millimetre divisions (1) use interim values of weight (1) add more weights (to increase the range) (1) move the ruler closer to the spring (1) use of pointer (1) repeat and average (1)	ignore more accurate add fixed values of weights eye level / no parallax	(2)

Question number	Answer	Additional guidance	Mark
(iv)	the coils are {pushed together /touching} (1) or spring is fully compressed /cannot be made shorter (1)		(1)

Q3.

Question Number:	Answer	Additional Guidance	Mark
(i)	<p>a description to include 4 of the following:</p> <ul style="list-style-type: none"> • note position of pointer before current is switched on (1) • measure position of pointer when current in coil (1) • (use an ammeter to) measure current (1) • calculate the extension / stretch of the spring (1) • use force (of attraction) is proportional to extension / stretch (of spring) (1) • repeat with different currents (1) 	<p>measure length of spring before current is switched on</p> <p>how far nail moves</p> <p>calculate force from spring constant and extension</p> <p>calibrate spring</p> <p>increase the current</p> <p>calculate the extension of the spring using new position of pointer minus starting position of pointer is worth 3 marks</p>	(4) AO 2 2

Question Number:	Answer	Additional Guidance	Mark
(ii)	<p>select and substitute (1)</p> <p>(E =) $\frac{1}{2} \times 24 \times 0.12^2$</p> <p>evaluation (1)</p> <p>(E =) 0.17 (J)</p>	<p>$\frac{1}{2} \times 24 \times 12^2$ max 1 mark</p> <p>accept answers that round down to 0.17 e.g. 0.1728</p> <p>POT error (e.g. 1728) max 1 mark</p> <p>award full marks for correct answer without working</p>	(2) AO 2 1

Q4.

Question Number:	Answer	Mark
(i)	70 (kPa)	(2) AO 3 1a

Question Number:	Answer	Mark
(ii)	between 46 and 48 (kPa)	(1) AO 3 1a

Question Number:	Answer	Additional guidance	Mark
(iii)	any one from: the atmosphere gets less dense / thinner / has fewer molecules (as height above sea level increases) (1) or there is less air/oxygen (as the height above sea level increases)(1)	accept particles less weight pushing down	(1) AO 1 1

Q5.

Question number	Answer	Additional guidance	Mark
	Any two from: height of atmosphere (above aeroplane) (1) density of atmosphere (1) the temperature (of the atmosphere) (1)	less air above the aeroplane accept oxygen for air in this context the air gets thinner the air gets colder	(2)

Q6.

Question number	Answer	Additional guidance	Mark
i	 D A and B are incorrect because they only show one force C is incorrect because the forces are in the wrong direction		(1)
Question number	Answer	Additional guidance	Mark
ii	substitution (1) $(F =) 20 \times (0.0)7$ evaluation (1) 1.4 (N)	award full marks for the correct answer without working allow 1 mark max for POT error	(2)

Q7.

Question Number	Answer	Mark
	<p>C 3</p> <p>C is the only correct answer.</p> <p>A is incorrect because it does not include the pressure of the water above the diver.</p> <p>B is incorrect because it only includes the pressure of 10m of water above the diver.</p> <p>D is incorrect because it includes the pressure 0r 30m of water above the diver.</p>	(1)

Q8.

Question Number:	Answer	Additional Guidance	Mark
	<p>an explanation linking:</p> <p>use of $P = \frac{F}{A}$ (1)</p> <p>area of piston Y is less than area of piston Z (1)</p> <p>(therefore) force K is less than force L (1)</p>	<p>accept answers in terms of work = force x distance</p> <p>accept reverse arguments</p> <p>accept K for piston Y and L for piston Z</p>	<p>(3)</p> <p>AO 3 2a</p> <p>AO 3 2b</p>

Q9.

Question number	Indicative content	Mark
	<p>Answers will be credited according to candidate's deployment of knowledge and understanding of the material in relation to the qualities and skills outlined in the generic mark scheme.</p> <p>The indicative (example) content below is not prescriptive and candidates are not required to include the material which is indicated as relevant. Additional content included in the response must be scientific and relevant.</p> <p style="text-align: center;">AO2</p> <p>Pressure</p> <ul style="list-style-type: none"> • difference in pressure between top and bottom of boat • top pressure is atmospheric • pressure on bottom of boat atmospheric plus that due to depth of water. <p>Unloaded boat</p> <ul style="list-style-type: none"> • density of boat less than density of water • floating objects are partially immersed • floating objects displace fluid / water • upthrust is due to the difference in pressure • upthrust is equal to the weight of the boat • upthrust is equal to the weight of fluid / water displaced <p>Boat with load</p> <ul style="list-style-type: none"> • the weight/density of the boat increases because of the load added • more upthrust is needed to balance the extra weight of the boat • more water has to be displaced to provide the upthrust • when the boat floats lower in the water it displaces more water • the weight of water displaced is the upthrust and is equal to the weight of the boat 	(6)

15.1 Stretching, Compression and Fluids

Level	Mark	Descriptor
	0	No rewardable material.
Level 1	1-2	The explanation attempts to link and apply knowledge and understanding of scientific ideas, flawed or simplistic connections made between elements in the context of the question. Lines of reasoning are unsupported or unclear. (AO2)
Level 2	3-4	The explanation is mostly supported through linkage and application of knowledge and understanding of scientific ideas, some logical connections made between elements in the context of the question. Lines of reasoning mostly supported through the application of relevant evidence. (AO2)
Level 3	5-6	The explanation is supported throughout by linkage and application of knowledge and understanding of scientific ideas, logical connections made between elements in the context of the question. Lines of reasoning are supported by sustained application of relevant evidence. (AO2)

Level	Mark	Additional Guidance	General additional guidance – the decision within levels
	0	No rewardable material.	e.g. - At each level, as well as content, the scientific coherency of what is stated will help place the answer at the top, or the bottom, of that level.
Level 1	1-2	<u>Additional guidance</u> Elements of physics present i.e. isolated knowledge of principles two unconnected statements from any section	<u>Possible candidate responses</u> pressure difference upthrust water displaced displacement floating
Level 2	3-4	<u>Additional guidance</u> Some knowledge of principles with a logical connection made in one section and statement from one other section	<u>Possible candidate responses</u> upthrust and weight are balanced /upthrust is equal to the weight of the boat when load added upthrust increases difference in pressure between the top and bottom of the boat
Level 3	5-6	<u>Additional guidance</u> Detailed knowledge of principles with logical connections made in two sections.	<u>Possible candidate responses</u> upthrust is equal to the weight of water displaced. when load is added, weight increases more water is displaced

Q10.

Question number	Answer	Additional guidance	Mark
	<p>an explanation linking</p> <p>the area (of contact between person and bed) is smaller when standing up (1)</p> <p>same weight (over smaller area) so the pressure is greater when standing up (1)</p>	<p>accept reverse arguments</p> <p>weight is more concentrated / not distributed /not spread across bed (when standing up)</p> <p>uses $p = F/A$ argument (as a consequence of the smaller area, pressure is bigger)</p>	(2) AO2

Q11.

Question Number	Answer	Additional guidance	Mark
	<p>substitution (1)</p> <p>$(E=) \frac{1}{2} \times 250 \times 0.30^2$</p> <p>evaluation 11 (1)</p> <p>unit (1) joule(s)/J</p>	<p>accept 37.5, 37, 38 only</p> <p>accept 11.25, 11.2, 11.3</p> <p>award full marks for the correct answer without working</p> <p>no POT error in evaluation</p> <p>independent mark j , Nm</p>	(3)

Q12.

Question Number	Answer	Additional guidance	Mark
(i)	substitution (1) $4.0 = k \times 0.06$ rearrangement (1) $\frac{4.0}{0.06} (=k)$ evaluation (1) 67 (N/m)	allow substitution and rearrangement in either order $k = \frac{F}{x}$ allow values that round to 67 (N/m) award full marks for the correct answer without working POT error 2 marks maximum	(3)
Question Number	Answer	Additional guidance	Mark
(ii)	(measurement of) original length (1) (measurement of) final length (1)	Accept measure length of spring for 1 mark	(2)

Q13.

Question number	Answer	Additional guidance	Mark
(i)	substitution (1) $(p) = 1000 \times 10 \times 0.200$ evaluation of pressure difference (1) 2000 final evaluation (1) 103000 (Pa)	accept e.c.f for addition of atmospheric pressure seen for 1mark award 1 mark for selecting correct equation if no other mark awarded award full marks for correct answer without working.	(3)

Question number	Answer	Additional guidance	Mark
(ii)	an explanation linking use of $P = h \times \rho \times g$ (1) no area in the equation (1)	P /pressure, ρ /density (and g /gravitational field strength) are constant/the same Area does not affect result h /height of water is independent of area P, ρ , and g are all constant gains 2 marks	(2)

Q14.

Question number	Answer	Additional guidance	Mark
	recall and substitution (1) $0.5 = k \times 13 \times 10^{-3}$ rearrangement (1) $\frac{0.5}{13 \times 10^{-3}}$ evaluation (1) 38 (N/m)	$k = \frac{F}{x}$ allow 38.5 (N/m) or 38.46 (N/m) or 39 (N/m) 0.04/0.038 (N/m) gains 2 marks 2958 (N/m) gains 1 mark (x^2 used in equation) award full marks for the correct answer without working	(3)

Q15.

Question Number:	Answer	Mark
	<p>Answers will be credited according to candidate's deployment of knowledge and understanding of the material in relation to the qualities and skills outlined in the generic mark scheme.</p> <p>The indicative (example) content below is not prescriptive and candidates are not required to include all the material which is indicated as relevant. Additional content included in the response must be scientific and relevant.</p> <ul style="list-style-type: none"> • same force at tip and head of the thumb tack • flat end has a large surface area • pointed end has a very small surface area • using pressure =force /area • at pointed end the pressure is large • large pressure , tip goes into wood • at flat end the pressure is much less • the flat end does not damage the thumb 	(1) AO 1 2

Level	Mark	Descriptor
	0	<ul style="list-style-type: none"> • No rewardable material.
Level 1	1-2	<ul style="list-style-type: none"> • Demonstrates elements of physics understanding, some of which is inaccurate. Understanding of scientific ideas lacks detail. (AO1) • Presents an explanation with some structure and coherence. (AO1)
Level 2	3-4	<ul style="list-style-type: none"> • Demonstrates physics understanding, which is mostly relevant but may include some inaccuracies. Understanding of scientific ideas is not fully detailed and/or developed. (AO1) • Presents an explanation that has a structure which is mostly clear, coherent and logical. (AO1)
Level 3	5-6	<ul style="list-style-type: none"> • Demonstrates accurate and relevant physics understanding throughout. Understanding of the scientific ideas is detailed and fully developed. (AO1) • Presents an explanation that has a well-developed structure which is clear, coherent and logical. (AO1)

Q16.

Question number	Answer	Additional guidance	Mark
i	recall (1) $P = \frac{F}{A}$ substitution (1) $(p) = \frac{2400}{0.8}$ evaluation $(P) = 3000 \text{ (Pa)}$ (1)	may be implied by a correct substitution award full marks for the correct answer without working	(3) AO2

Question number	Answer	Additional guidance	Mark
ii	an explanation linking greater pressure (on bottom of tank) (1) with greater force due to water (above bottom of tank) (1)	 more weight of water more depth/height of water ignore simply 'more water' or 'greater amount of water'	(2) AO1

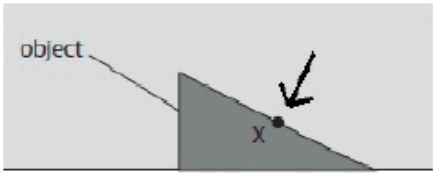
Question number	Answer	Additional guidance	Mark
iii	 <p>an arrow perpendicular to the sloping side and pointing towards X</p>	judge by eye	(1) AO1